

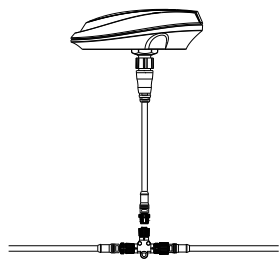

## Wiring

Connect the Precision™ 9 compass to your NMEA 2000® network using the supplied tee connector.



## Calibration

After installing and wiring your compass, you should calibrate it to compensate for the deviation (local magnetic field) on board the vessel, and adapt the sensors to the earth's magnetic field strength.

Your Precision™ 9 compass supports two calibration modes:

- Auto calibration
- Manual calibration

### Auto calibration

There are 4 different auto calibration modes. In all modes, the compass continuously collects and calculates new calibration parameters during normal use on the water - the difference is in how and when new parameters are applied.

The default mode is **Auto**, and for most users it's not necessary to change this. However, if you wish to make sure the compass doesn't change its calibration, you can set it to **Locked** once you're satisfied with the performance.

To change the mode, go to your compatible display unit and find your Precision™ 9 compass in the devices list, usually under **Settings > Network (or Boat network) > Device list (or Devices) > Precision-9**. Open the compass configuration screen and select a different mode from the **Compass auto calibration** drop-down.

→ **Note:** If the **Compass auto calibration** option isn't available on your display unit, go directly to the **Manual calibration** section of this installation guide.

Mode	Behavior
<b>Auto</b>	In this mode, the compass will phase in new calibration parameters only if the parameters in use are deemed invalid (their performance has dropped below a certain threshold) and the new parameters are proven to be better. Parameters can become invalid due to changes in the magnetic field. This could be from moving to a different geographic position. It takes around 20 minutes to phase in the new settings.
<b>Locked</b>	In this mode, the compass won't change calibration parameters in use by itself. If new parameters are deemed better than the current ones, the following warning displays, "Parameters in use are not valid". In this situation, you can switch to <b>Auto</b> or <b>On</b> mode and phase in the new settings. <b>Locked</b> mode is suitable for vessels operating in a small geographical area with no big variation in the local magnetic field.
<b>On</b>	In this mode, the compass will phase in new parameters if they are deemed better (their performance is over a certain threshold) than the parameters in use. It takes around 20 minutes to phase in the new settings.
<b>Off</b>	In this mode, no auto calibration parameters are used, and the compass uses manual calibration.

### Statuses and warnings

Calibration status and warning information also displays on the compass configuration screen.

Status	Description
Is not calibrated	The needed magnetic raw data is not yet collected.
Is calibrating	New calibration parameters have been found, and are being phased in.
Is calibrated	Calibration parameters have been found and are being used.
---	Auto calibration mode is set to <b>Off</b> .

Warning	Description
First calibration in progress	Data for first calibration is being collected.
No warning	Performance of current parameters is deemed good.
Parameters in use are not valid	Current parameters are not valid. If this is seen when the mode is <b>Locked</b> , the mode should at least temporarily be set to <b>On</b> or <b>Auto</b> , to switch parameters.
---	Auto calibration mode is set to <b>Off</b> .

## Manual calibration

To manually calibrate your Precision™ 9 compass, go to your compatible display unit and find it in the devices list, usually under **Settings > Network** (or **Boat network**) > **Device list** (or **Devices**) > **Precision-9**. Select **Calibrate** or **Recalibrate compass** (depending on your display unit) and follow the on-screen instructions.

→ **Note:** If your display unit supports auto calibration, the auto calibration mode must first be set to **Off**.

Important points:

- Manually calibrate your compass in calm sea conditions with minimal wind and current.
  - Ensure there's enough open water around the vessel to maneuver a turn of about 390 degrees.
  - Maintain a turn rate of about 2-3 degrees per second until you see a notification that the calibration is complete.
- **Note:** If an autopilot is configured, a setup guide automatically takes you through compass calibration, without having to go through the **Settings** menu.
- **Note:** For optimal performance, you should recalibrate the compass if the vessel has traveled far from where it was previously calibrated. Recalibration may be required because the strength of the earth's magnetic field varies in different geographic locations.

## Data

To see the data your compass is generating, select **Data** or **Show details** (depending on your display unit) under **Settings > Network** (or **Boat network**) > **Device list** (or **Devices**) > **Precision-9**.

## Offsets

After calibrating your compass, you should apply offsets for the heading, pitch and roll outputs to compensate for any mounting alignment errors.

### To apply pitch and roll offsets:

1. Ensure the vessel is stationary at the dock, loaded in normal trim.
2. Open the compass data screen by selecting **Data** or **Show details** (depending on your display unit) and take note of the pitch and roll output values.
3. Open the compass configuration screen and adjust the pitch and roll offsets.
4. Return to the data screen to confirm the pitch and roll output values are 0.

The heading offset compensates for any difference between the vessel's center line (A) and the compass lubber line (B).

### To apply the heading offset:

1. Open the compass data screen by selecting **Data** or **Show details** (depending on your display unit) and take note of the heading output value.
  2. If necessary, change the heading reference on your display unit (**Settings > Units** (or **Preferences**) > **Heading**) so it's the same as the compass heading (°M or °T).
  3. Use a chart or chartplotter to find the bearing from the vessel position to a visible object.
  4. Steer the vessel so its center line aligns with the bearing line pointing towards the object.
  5. Open the compass configuration screen and adjust the heading offset so the bearing value and the compass heading output are the same.
- **Note:** The compass heading and bearing values may be damped. Allow time for the heading and bearing values to settle before applying offset.

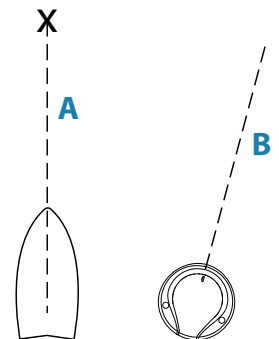

## Dimensions

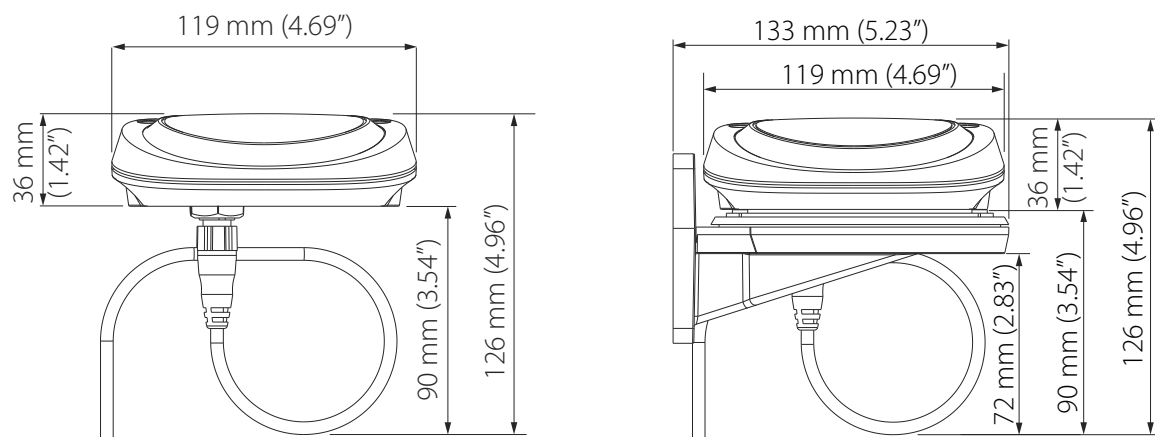

# Technical specifications

Module weight	165 g (5.8 oz)
Bracket weight	130 g (4.6 oz)
Supply and interface	8-16 V via NMEA 2000®
Power consumption	0.4 W
Calibration	Automatic or manual
Repeatability	± 1.0° (or better)
Roll/pitch range	± 45°
Heading accuracy	± 2° after calibration
<b>NMEA 2000®</b>	
Load equivalence no. (LEN)	1
Ports (input/output)	1
Output	Messages: PGN 127250, 127251, 127257, 127252 Data: Magnetic heading (20 Hz), rate of turn (20 Hz), pitch/roll (10 Hz), heave (10 Hz) Status and warning information
<b>Dynamic performance</b>	
- with random excitation of ± 10° at max 1 Hz	Heading error <2°
- with heading step input of 90° at a rate of 10°/s	Heading error 10 sec. after turn <2°
Environmental protection	IPX7
Compass safe distance	0.5 m (1.7 ft)
<b>Temperature range</b>	
Operation temperature	-25 to +65°C (-13 to +149°F)
Storage temperature	-30 to +70°C (-22 to +158°F)
Cable supplied	4.5 m (15 ft) incl. connector
Mounting	Horizontal or vertical surface
Material	Plastic

## Disclaimer

Warning: Refer to important safety information in the user app guides, product documentation and review all warnings, limitations, and disclaimers before using this product.

This product is not a substitute for proper training and prudent seamanship. It is the owner's sole responsibility to install and use the equipment in a manner that will not cause accidents, personal injury or property damage. The user of this product is solely responsible for observing maritime safety practices.

Navigational features that appear in this guide are not a substitute for proper training and prudent seamanship. They do not replace a human navigator and SHOULD NOT be relied on as a sole or primary source of navigation. It is the operator's sole responsibility to use more than one navigational methods to ensure the route suggested by the system is safe.

BRUNSWICK CORPORATION AND ITS SUBSIDIARIES, BRANCHES AND AFFILIATES DISCLAIM ALL LIABILITY FOR ANY USE OF THIS PRODUCT IN A WAY THAT MAY CAUSE ACCIDENTS, DAMAGE OR THAT MAY VIOLATE THE LAW.

This document represents the product at the time of publishing. Brunswick Corporation and its subsidiaries, branches and affiliates reserve the right to make changes to the product and/or specifications at any time without notice. Please contact your nearest distributor if you require any further assistance.

## Compliance statements

### Declarations

The relevant declarations of conformity are available at: [www.simrad-yachting.com](http://www.simrad-yachting.com), [www.lowrance.com](http://www.lowrance.com) and [www.bandg.com](http://www.bandg.com).

### United Kingdom

The Precision™ 9 compass complies with UKCA under Electromagnetic Compatibility Regulations 2016.

### Europe

The Precision™ 9 compass complies with CE under Electromagnetic Compatibility Directive 2014/30/EU.

### United States of America

Note: The user is cautioned that any changes or modifications not expressly approved by the party responsible for compliance could void the user's authority to operate the equipment.

### Australia and New Zealand

The Precision™ 9 compass complies with the requirements of Level 2 devices of the Radiocommunications (Electromagnetic Compatibility) Standard 2017.

Note: This product includes code from the Eigen project licensed under the MPL v2.0 license, available from <http://eigen.tuxfamily.org/>.

## Copyright

© 2023 Navico Group. All Rights Reserved. Navico Group is a division of Brunswick Corporation.

## Trademarks

®Reg. U.S. Pat. & Tm. Off. and ™ common law marks.

Visit [www.navico.com/intellectual-property](http://www.navico.com/intellectual-property) to review the global trademark rights and accreditations for Navico Group and other entities.

## Warranty

The warranty card is supplied as a separate document. In case of any queries, refer to the brand website of your unit or system.